

Addendum

Planning Committee

Dear Councillor,

Planning Committee - Wednesday, 28 June 2023, 7.30 pm

I enclose, for consideration at the meeting of the Planning Committee to be held on Wednesday, 28 June 2023 at 7.30 pm, the following reports which were unavailable when the agenda was published.

Mari Roberts-Wood
Managing Director

4. **Addendum to the agenda(Pages 3 - 16)**

To note the addendum tabled at the meeting which provides an update on the agenda of planning applications before the Committee.

For enquiries regarding this addendum;

Contact: 01737 276182

Email: democratic@reigate-banstead.gov.uk

Published 28 June 2023



This page is intentionally left blank

ADDENDUM

MEETING OF THE PLANNING COMMITTEE

TUESDAY 28th JUNE 2023

ITEM NO: 6

PLANNING APPLICATION: 23/00654/F Just Retirement Roebuck House Bancroft Road Reigate RH2 7RP

Plans

Vehicle tracking plans have been provided demonstrating vehicular movements of a medium sized vehicle entering and exiting a number of proposed parking spaces in both forward and reverse gears. These plans (21037 TR02 A) can be found in Appendix A of the addendum.

Highway Matters

Since the publication of the report the applicant has confirmed that the 4 spaces originally allocated within the development for the office space will be now allocated for residential. This means that the development will continue to meet the County adopted parking standards for the office space as the standards for this use are a maximum.

The additional spaces to be allocated for residential is welcomed and means that all spaces laid out will serve for residential and can be secured by planning condition.

Following publication of the report, it has been noted that 3 of the existing parking spaces (1, 3, and 9) as shown on plan number AP261_P101_A, which are proposed for use by future residents of Roebuck House, are impeded by existing pillars within the undercroft of the building. Whilst these spaces are pre-existing and capable of some use, this issue has been reviewed by the County Highway Authority (CHA), who consider that the narrow width of these spaces would make them difficult to enter and exit.

The CHA have advised that if either space 1, 2 or 3 were removed, along with space 9, this would result in a more appropriate layout and would make it clear as to where parking can take place.

To capture the additional spaces and a more optimum parking layout, number and management of the spaces, it is recommended that condition is amended 9 to require a parking layout and management plan.

Agenda Item 4

Conditions

The below condition 9 has been amended as follows:

9. Notwithstanding the submitted plan AP261 P101 Rev A the development hereby approved shall not be first occupied until a revised parking layout and management plan has been submitted to and approved in writing by the Local Planning Authority. The parking layout and management plan shall include numbers of spaces, markings and details of any management including allocation of spaces.

The residential units shall not be occupied until the approved parking layout and management plan has been implemented in accordance with the approved details and such that it has been laid out within the site for vehicles to be parked and for vehicles to turn so that they may enter and leave the site in forward gear in, and the layout and markings shall thereafter be retained.

Reason: The above conditions are required in order that the development should not prejudice highway safety nor cause inconvenience to other highway users and to accord with the NPPF and Reigate and Banstead Development Management Plan policy TAP1.

ITEM NO: 7

PLANNING APPLICATION: 22/02835/F – JOSIL, WATERHOUSE LANE, KINGSWOOD

Report

The following corrections are made to the case officer report, which are highlighted in bold italics:

Summary

This is a full application for the demolition of an existing detached dwelling and the erection of 1x detached 5 bed dwelling and a pair of ***semi-detached 4 bed dwellings*** to the north side of Waterhouse Lane in Kingswood.

Paragraphs 4.3, 6.6, 6.11, 6.17 all refer to House C having an attached single garage. This garage was amended on 17 January following the submission of amended plans. It is now part of the internal layout of the house, with parking contained to the front of the house. This is shown on amended floor plan 22.073.101A

4.7 The below table has been updated to include reference the density of the existing site, the proposed development and densities of the surrounding area.

Agenda Item 4

Site area	0.18 Ha
Existing use	Residential (C3)
Proposed use	Residential (C3)
Existing parking spaces	2
Proposed parking spaces	6
Parking standard	DMP Accessibility Level - Medium 2 parking spaces required per dwelling, 6 required in total.
Number of affordable units	0
Net increase in dwellings	2
Existing Density	5.5 dwellings per hectare (d.p.h)
Proposed Density	16.6 d.p.h
Surrounding Densities	Garden Farm Close 14.8 d.p.h Copt Hill Lane 11.6 d.p.h Alcocks Lane (east) 4.3 d.p.h Alcocks Lane (west) 5.8 d.p.h Cophthorne 48.3 d.p.h

Trees and Landscaping

The submitted landscape scheme is ornamental rather than providing trees and understorey that will provide an enduring landscape benefit to the site and local area. As such a landscape condition is suggested, requiring further details to be submitted for approval:

CONDITIONS

1.

Plan Type	Reference	Version	Received
Site Layout Plan	22.073.001		17.01.2023
Floor Plan	22.073.002		17.01.2023
Floor Plan	22.073.003		17.01.2023
Elevation Plan	22.073.004		17.01.2023
Elevation Plan	22.073.005		17.01.2023
Section Plan	22.073.006		17.01.2023
Floor Plan	22.073.103		17.01.2023

Agenda Item 4

Elevation Plan	22.073.110		17.01.2023
Elevation Plan	22.073.111		17.01.2023
Section Plan	22.073.120		17.01.2023
Section Plan	22.073.121		17.01.2023
Street Scene	22.073.130		17.01.2023
Elevation Plan	22.073.113A		17.01.2023
Elevation Plan	22.073. 112A		17.01.2023
Floor Plan	22.073. 101A		03.02.2023
Site Layout Plan	22.073. 100A		03.02.2023
Landscaping Plan	986-L-02		28.12.2022
Landscaping Plan	986-L-01	B	
Location Plan	00201		28.12.2022
Phasing Plan	22.073.000A		08.06.2022

14. No development above groundworks of either phase shall commence on site until a scheme for the landscaping of each phase including the retention of existing landscape features has been submitted to and approved in writing by the Local Planning Authority. Landscaping schemes shall include details of hard and soft landscaping, including any tree removal/retention, planting plans, written specifications (including cultivation and other operations associated with tree, shrub, and hedge or grass establishment), schedules of plants, noting species, plant sizes and proposed numbers/densities and an implementation and management programme.

All hard and soft landscaping work shall be completed in full accordance with the approved scheme, prior to first occupation of each phase or within the first planting season following completion of each phase of the development hereby approved or in accordance with a programme agreed in writing with the Local Planning Authority.

All new tree planting shall be positioned in accordance with guidelines and advice contained in the current British Standard 5837: Trees in Relation to Construction.

Any trees shrubs or plants planted in accordance with this condition which are removed, die or become damaged or become diseased within five years of planting shall be replaced within the next planting season by trees, and shrubs of the same size and species.

Reason: To ensure good arboricultural and landscape practice in the interests of the maintenance of the character and appearance of the area and to comply with Reigate and Banstead Borough Development Management Plan 2019 policies NHE3, DES1 and DES3, and the recommendations within British Standards including BS8545:2014 and British Standard 5837:2012.

15. No development above groundworks of either phase shall commence on site until the developer obtains the Local Planning Authority's written approval of details of both existing and proposed ground levels and the proposed finished ground floor levels of the buildings. The development shall be carried out in accordance with the approved levels.

Reason: To ensure the Local Planning Authority are satisfied with the details of the proposal and its relationship with adjoining development and to safeguard the visual amenities of the locality with regard to Reigate and Banstead Development Management Plan 2019 Policy DES1.

Plans

Two CGI drawings have been provided showing the detail of the proposed dwellings. These can be found in Appendix B of the addendum.

ITEM NO: 9

PLANNING APPLICATION: 23/00970/HHOLD 144 BALCOMBE ROAD, HORLEY RH6 9DS

Representations

There has been a representation received since the publication of the committee report. Objections have been raised on the following grounds:

- Loss of private view
- Out of character with surrounding area
- Overlooking and loss of privacy
- Overshadowing

The objections are from the attached neighbouring property No. 142 in regard to the rear extension. Concern related to the 45-degree line in the horizontal plane, overlooking from an elevated position, an impact on private view and the impact on the character of the area. The impact on this neighbouring property has been considered under section 6.10 of the committee report whilst the design and impact on the character of the area has been considered in section 6.3-6.5 inclusive.

To further clarify, the matters raised in the report and via the comment received, the 45-degree line taken from the rear window of this neighbour, whilst minimally intersecting in the horizontal plane, would comfortably pass in the vertical. This is considered acceptable in regard to an overshadowing relationship as identified in section 4.4 and figure 5 of the Council's Supplementary Planning Guidance (SPG) on Householder Extension and Alterations.

Agenda Item 4

With regard to overlooking from an elevated position, only rear facing windows would impact this neighbour and it is considered that the positioning of the windows would not allow for overlooking over and above the existing relationship or as is typical of dwellings in the urban area.

Right to a private view is not a material planning consideration. However, the outlook from this rear bedroom window has been assessed and is considered acceptable as a result of the stepped in position of the extension from the adjoining boundary. No specific comments were made in respect of design.

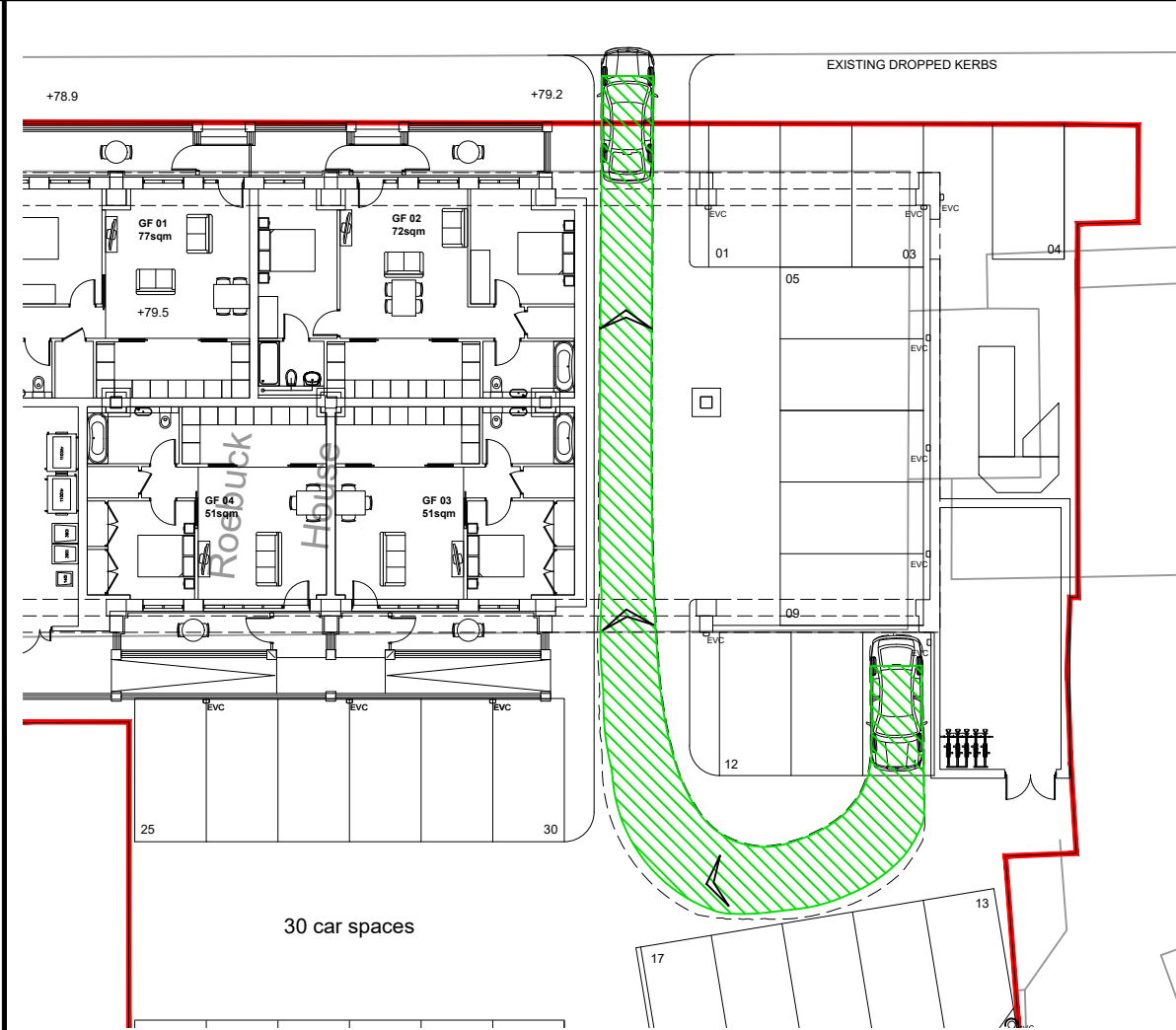
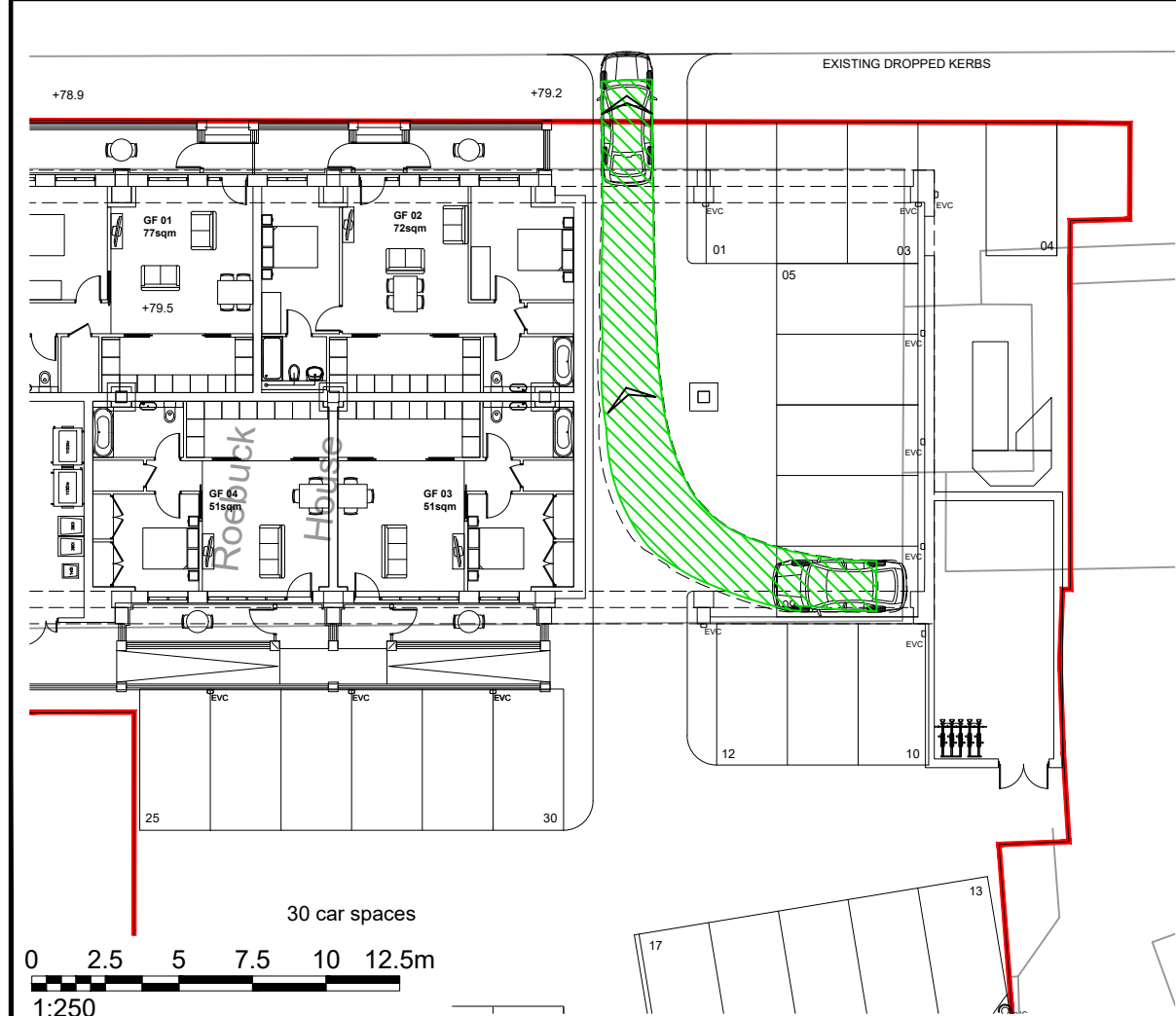
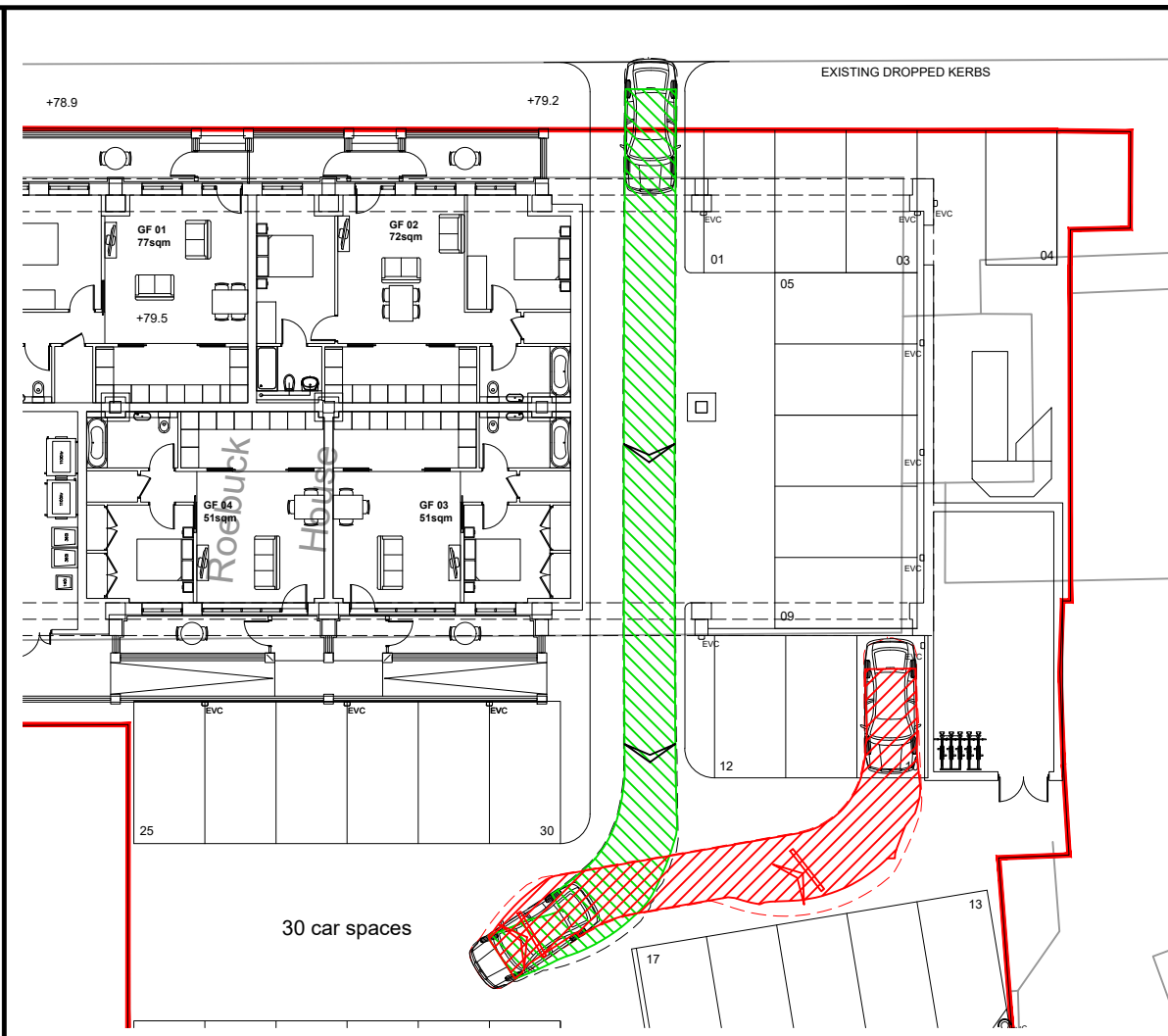
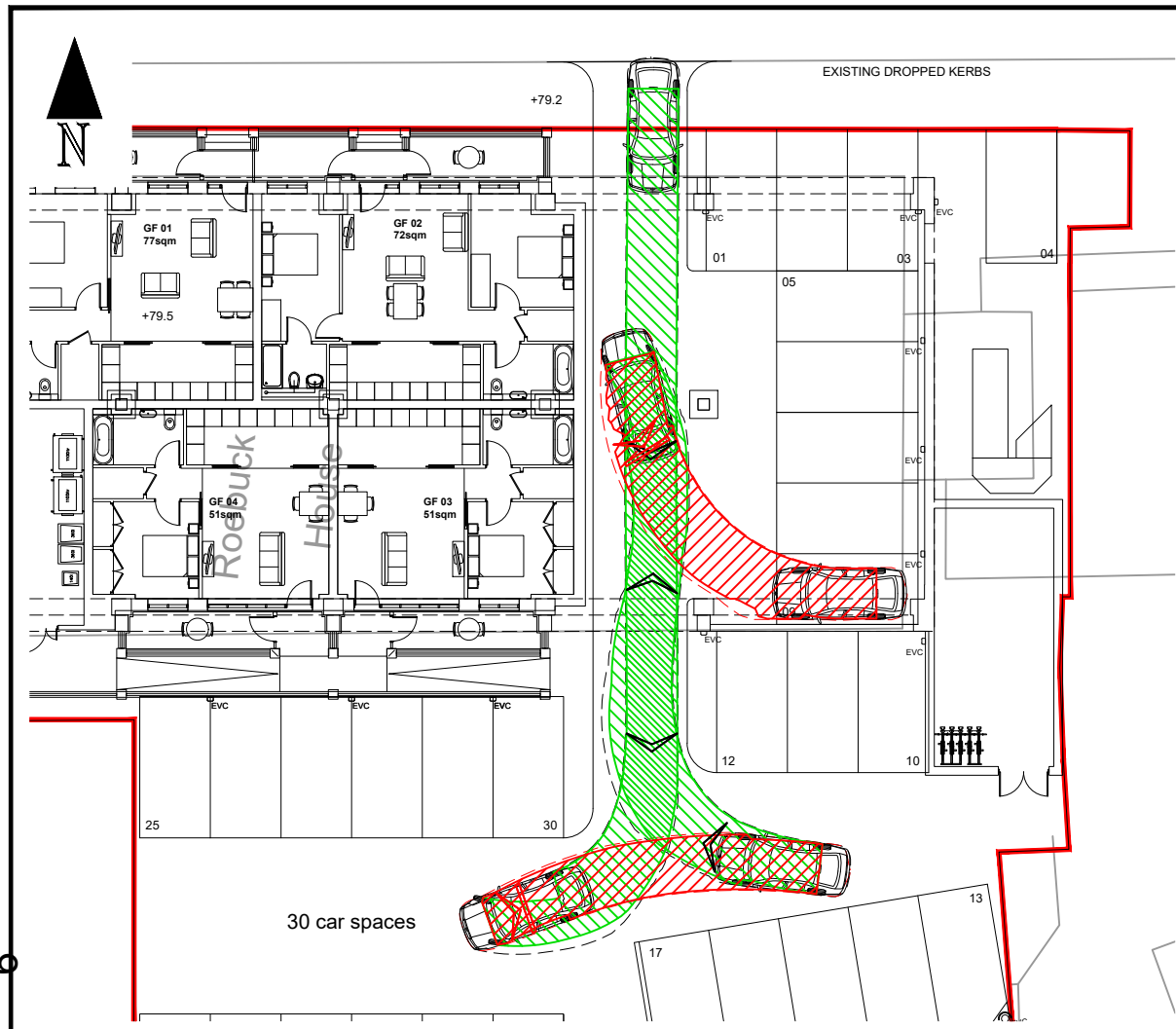

NOTES:

1. Do not scale from this drawing.
2. This drawing to be read & printed in colour.
3. This drawing is for illustrative purposes only, and not for construction.

MEDIUM SIZE CAR (Skoda Octavia)

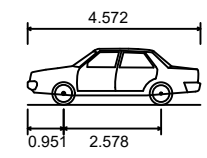

Overall Length	4.572m
Overall Width	1.769m
Overall Body Height	1.488m
Min Body Ground Clearance	0.249m
Max Track Width	1.713m
Lock to Lock Time	4.00s
Kerb to Kerb Turning Radius	5.100m

FORWARD MOVEMENTS
(design speed - 0.1kph)

REVERSE MOVEMENTS
(design speed - 0.1kph)

Appendix A

A	Vehicle Tracking Updated	AEG	KH	23.06.23
REV	DETAILS	DRAWN	CHECKED	DATE

CLIENT
Roebuck Close Ltd

PROJECT
Roebuck House, Reigate

DRAWING TITLE
Vehicular Swept Paths Analysis using Medium Size Car (Sheet 1 of 6)

SCALE: 1:250 SIZE: A3

DRAWN BY: DW CHECKED BY: KH DATE: 21.06.2023

Pulsar
TRANSPORT PLANNING

48 Charlotte Street, London, W1T 2NS
Tel: 020 3701 0400
www.pulsartransport.co.uk

PROJECT REF	DWG NO	REV
21037	TR02 (1)	A

Agenda Item 4

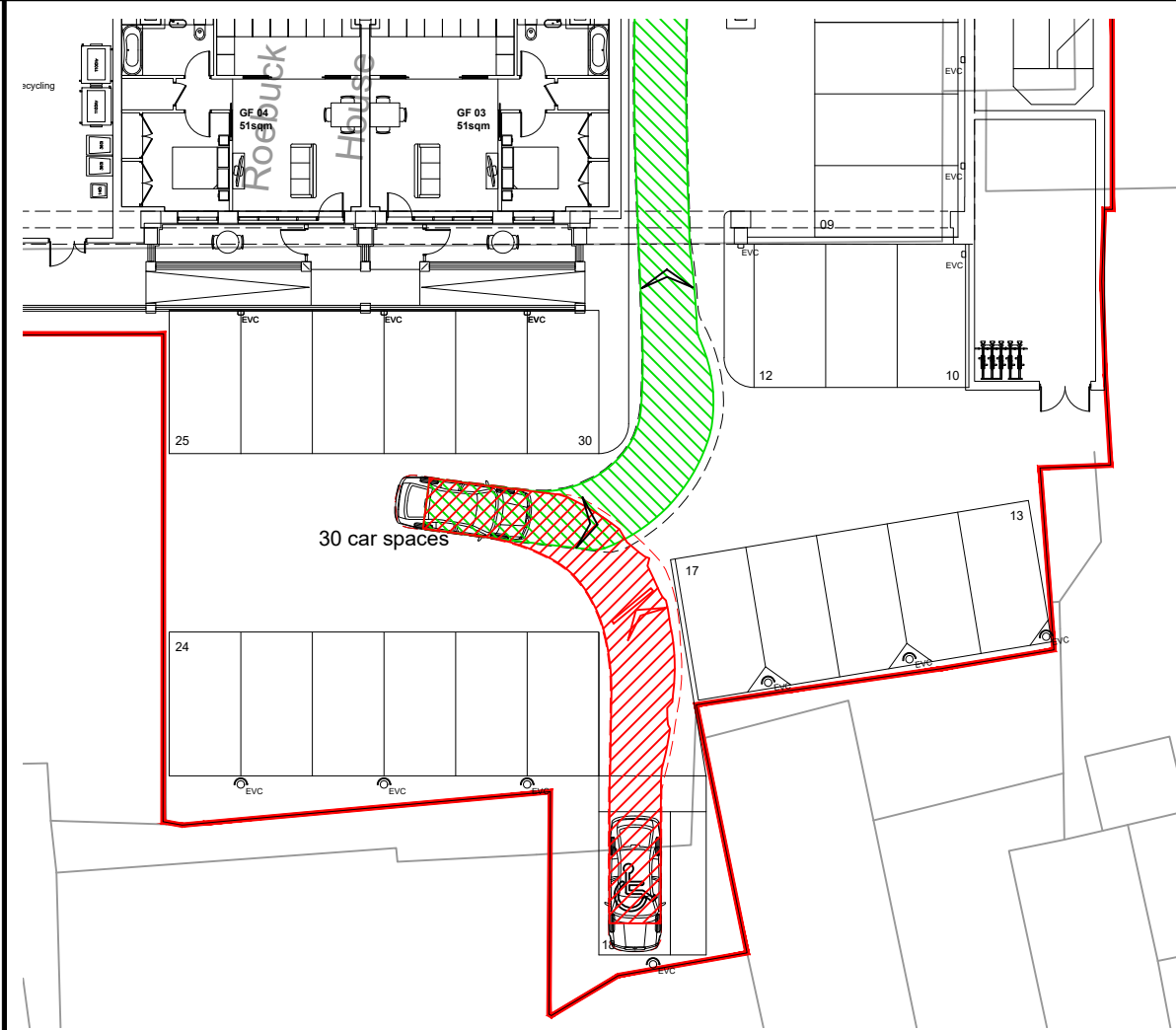
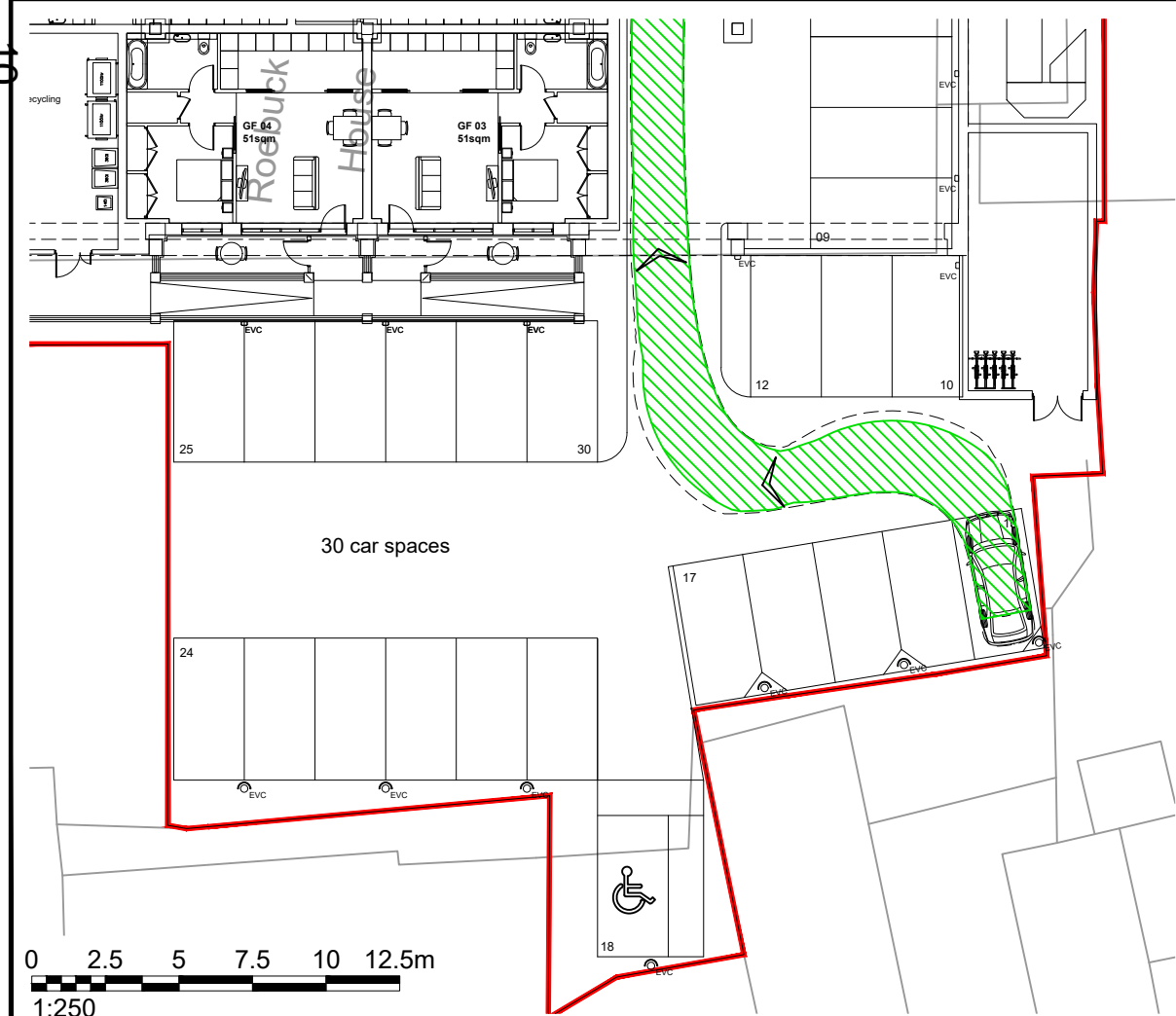
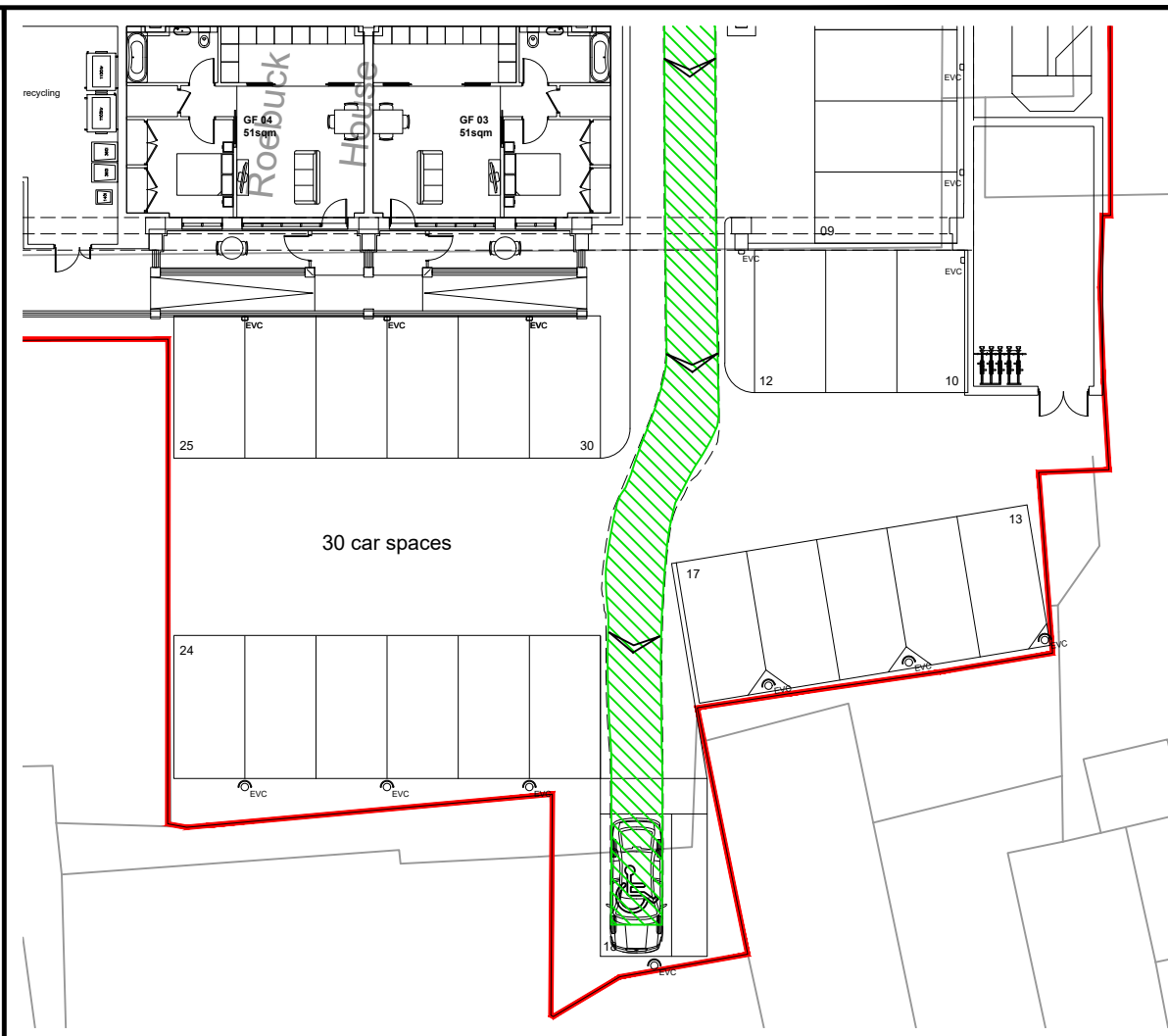
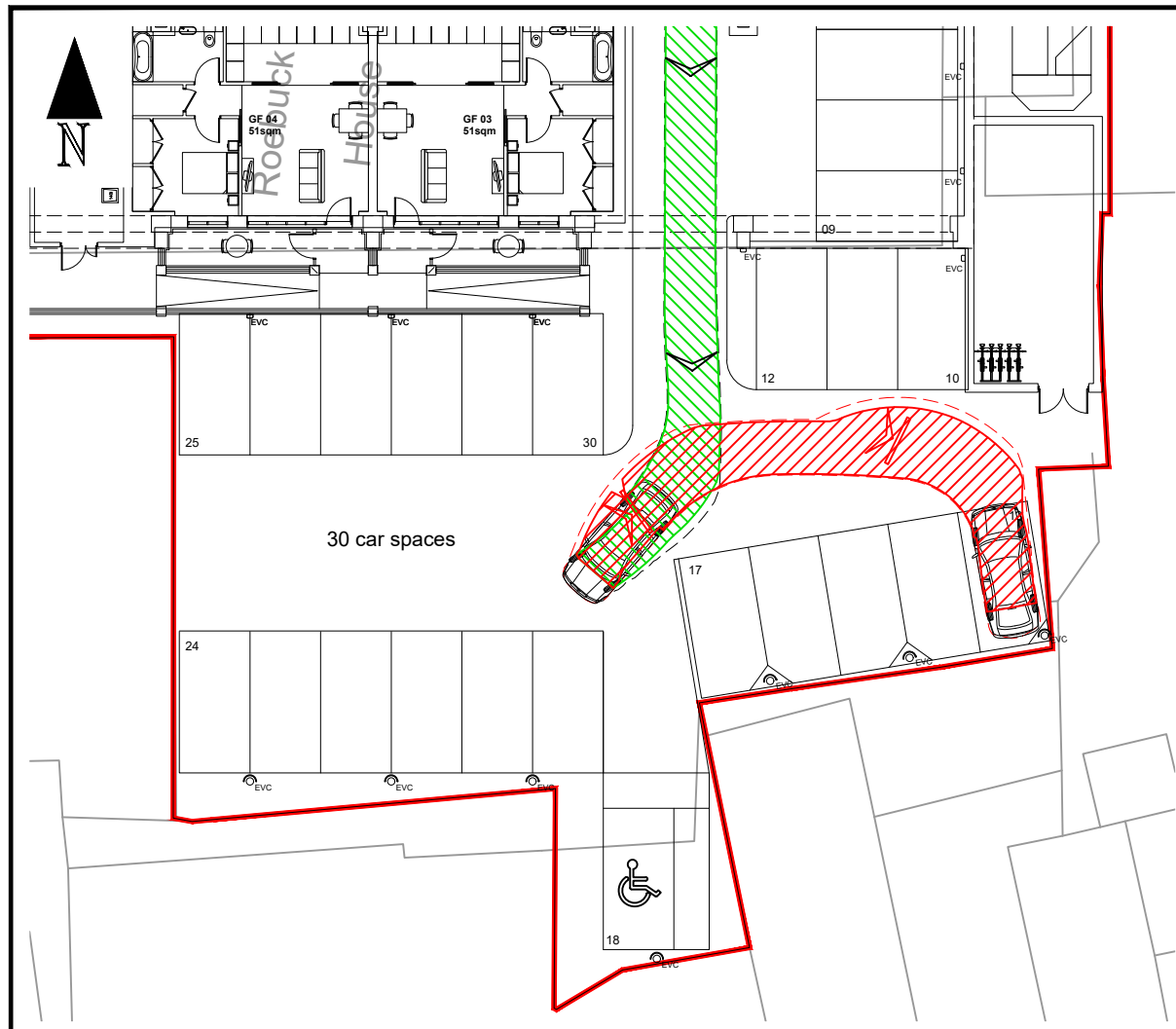

- NOTES:**
1. Do not scale from this drawing.
 2. This drawing to be read & printed in colour.
 3. This drawing is for illustrative purposes only, and not for construction.

MEDIUM SIZE CAR (Skoda Octavia)

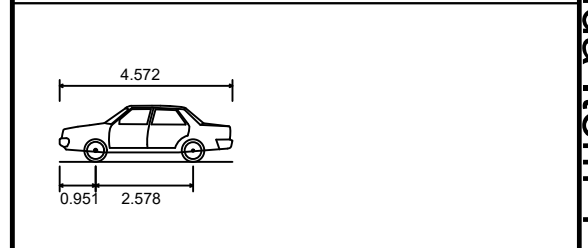

Overall Length	4.572m
Overall Width	1.769m
Overall Body Height	1.488m
Min Body Ground Clearance	0.249m
Max Track Width	1.713m
Lock to Lock Time	4.00s
Kerb to Kerb Turning Radius	5.100m

- FORWARD MOVEMENTS (design speed - 0.1kph)
- REVERSE MOVEMENTS (design speed - 0.1kph)

Appendix A

A	Vehicle Tracking Updated	AEG	KH	23.06.23
REV	DETAILS	DRAWN	CHECKED	DATE

CLIENT
Roebuck Close Ltd

PROJECT
Roebuck House, Reigate

DRAWING TITLE
Vehicular Swept Paths Analysis using Medium Size Car (Sheet 2 of 6)

SCALE: 1:250 SIZE: A3

DRAWN BY: DW CHECKED BY: KH DATE: 21.06.2023

Pulsar
TRANSPORT PLANNING

48 Charlotte Street, London, W1T 2NS
Tel: 020 3701 0400
www.pulsartransport.co.uk

PROJECT REF	DWG NO	REV
21037	TR02 (2)	A

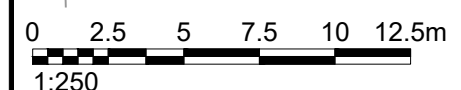

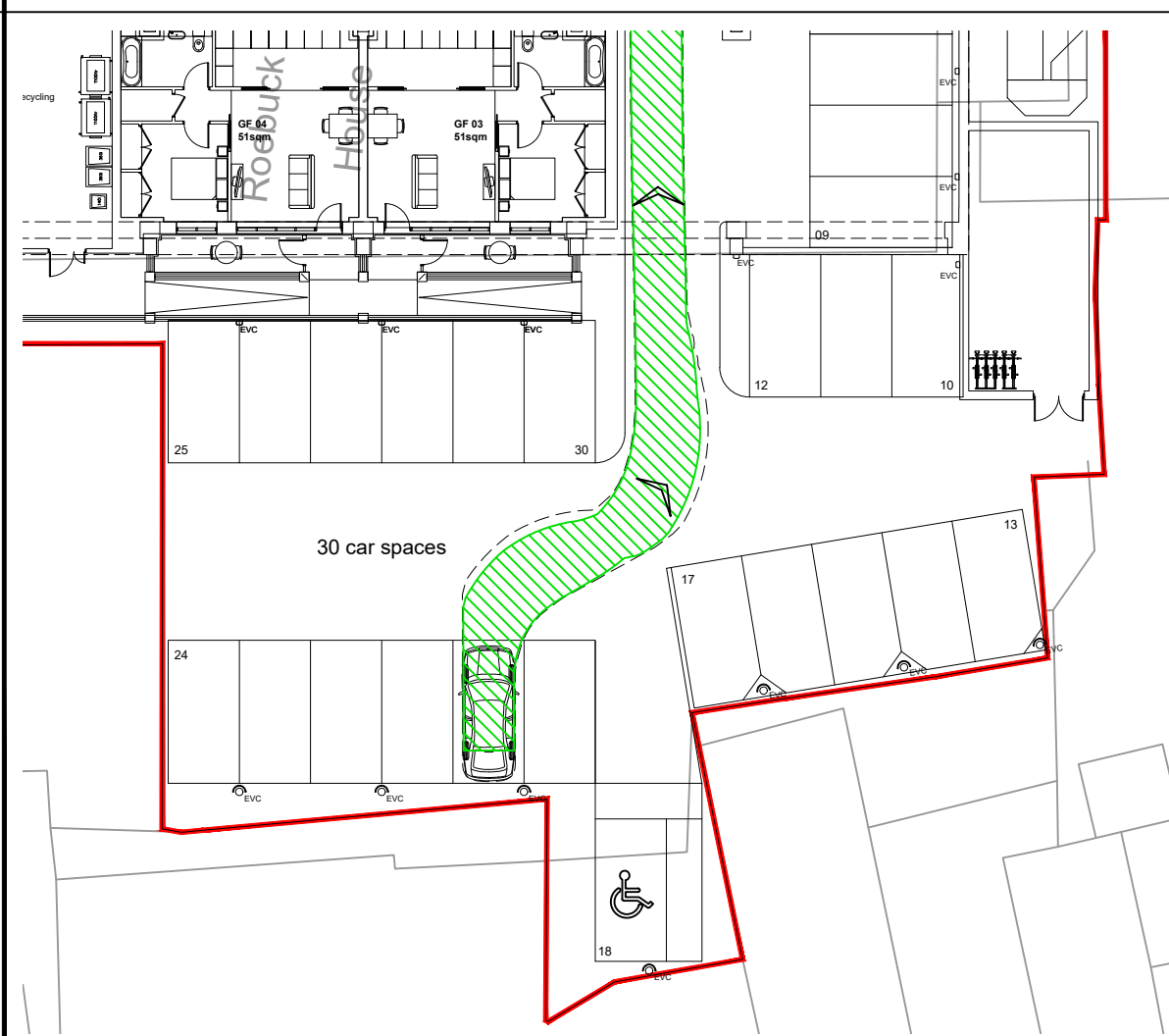
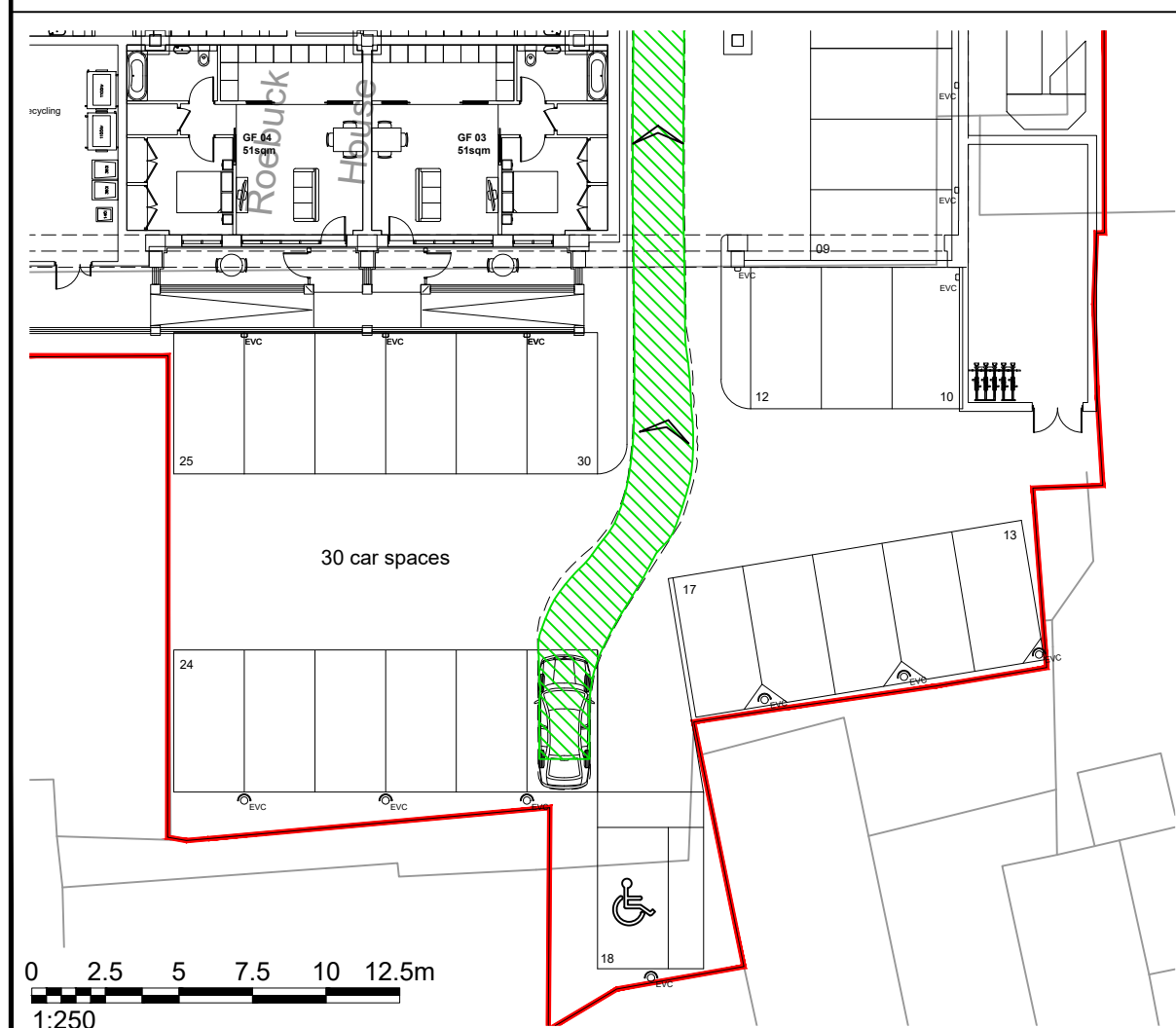
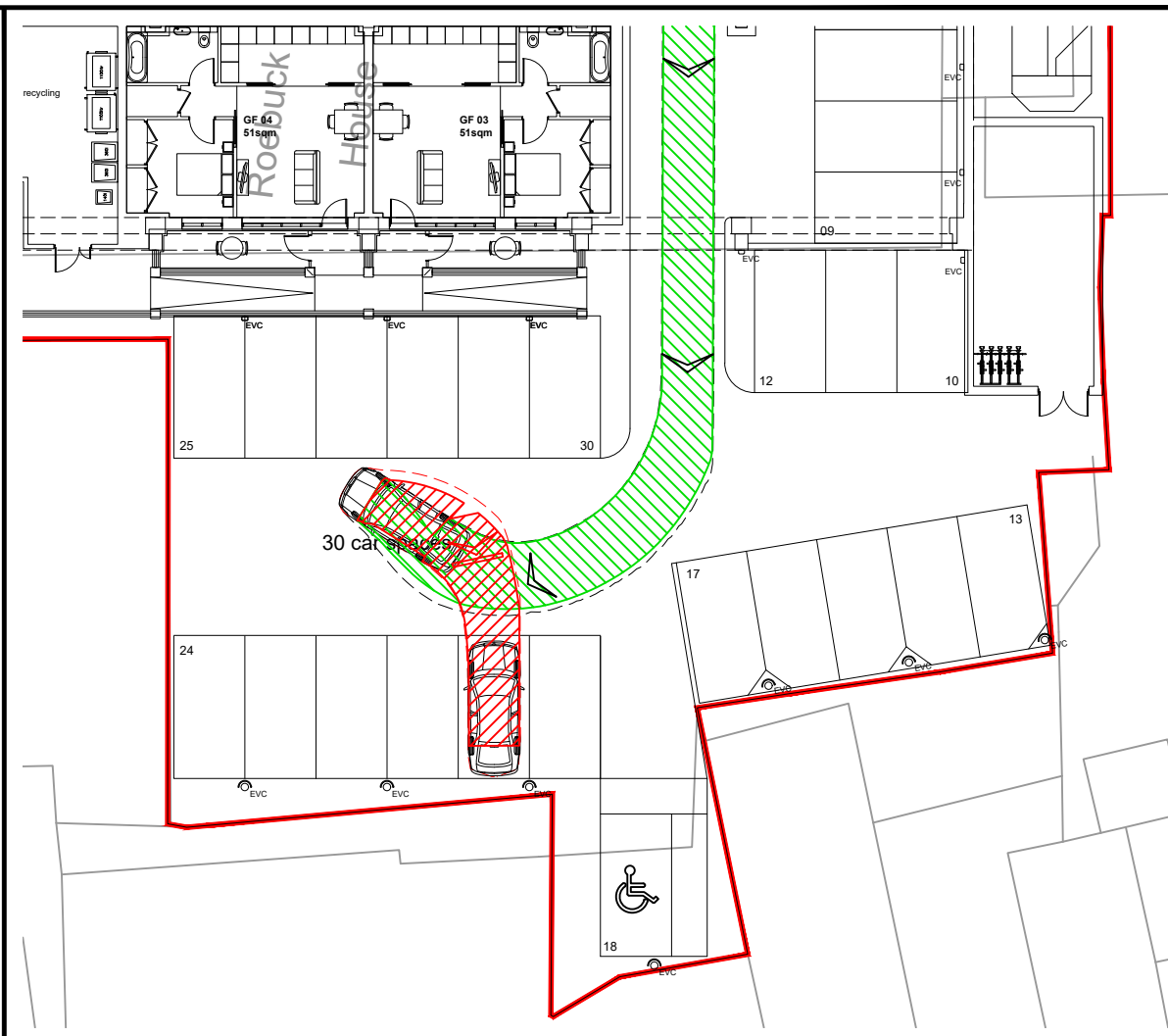
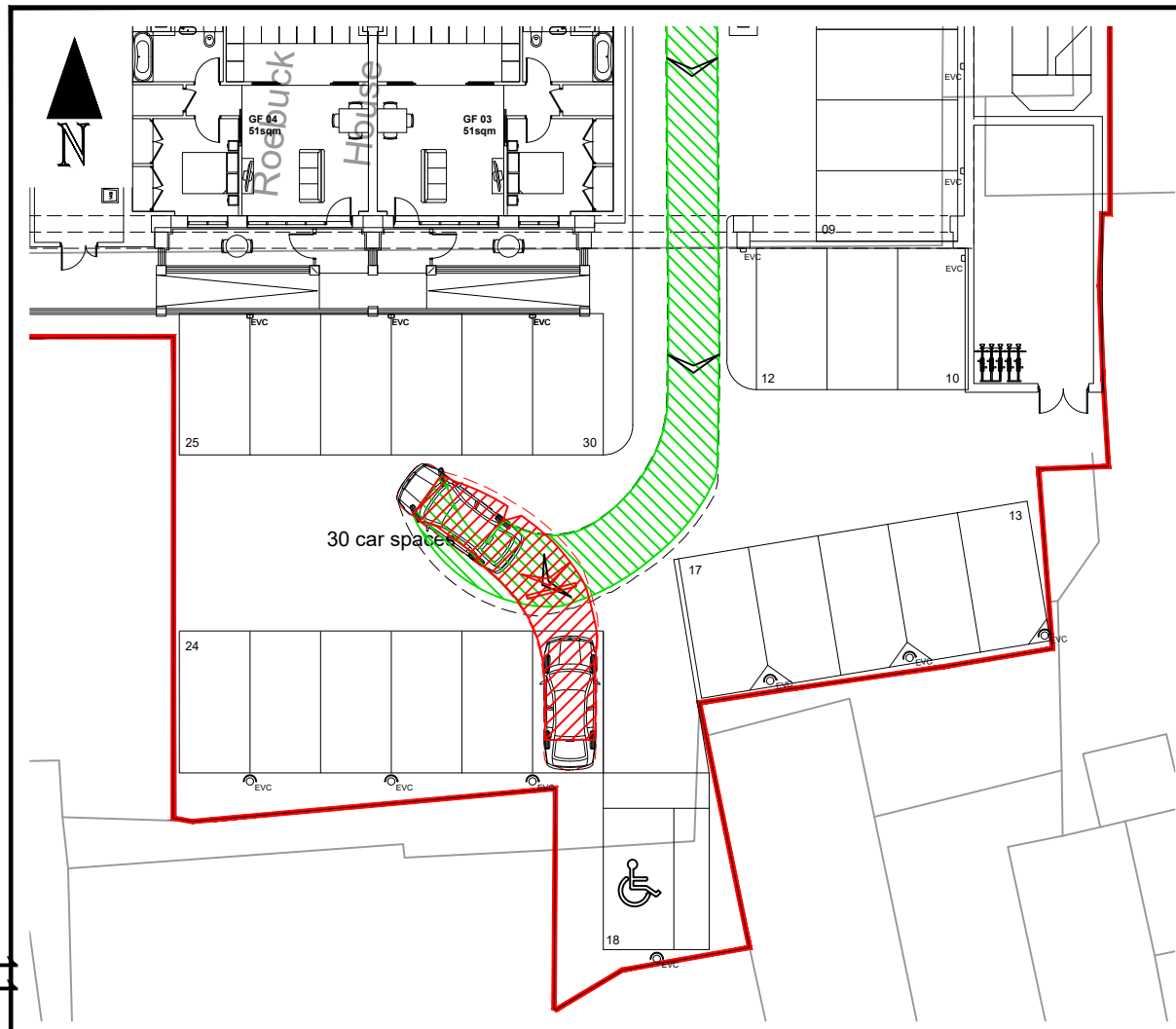

- NOTES:**
1. Do not scale from this drawing.
 2. This drawing to be read & printed in colour.
 3. This drawing is for illustrative purposes only, and not for construction.

MEDIUM SIZE CAR (Skoda Octavia)

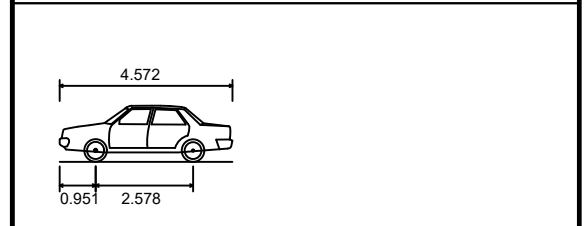

Overall Length	4.572m
Overall Width	1.769m
Overall Body Height	1.488m
Min Body Ground Clearance	0.249m
Max Track Width	1.713m
Lock to Lock Time	4.00s
Kerb to Kerb Turning Radius	5.100m

- FORWARD MOVEMENTS (design speed - 0.1kph)
- REVERSE MOVEMENTS (design speed - 0.1kph)

Appendix A

A	Vehicle Tracking Updated	AEG	KH	23.06.23
REV	DETAILS	DRAWN	CHECKED	DATE

CLIENT	Roebuck Close Ltd		
PROJECT	Roebuck House, Reigate		
DRAWING TITLE	Vehicular Swept Paths Analysis using Medium Size Car (Sheet 3 of 6)		
SCALE	1:250	SIZE	A3
DRAWN BY	DW	CHECKED BY	KH
DATE	21.06.2023		
48 Charlotte Street, London, W1T 2NS Tel: 020 3701 0400 www.pulsartransport.co.uk			
PROJECT REF	DWG NO	REV	
21037	TR02 (3)	A	

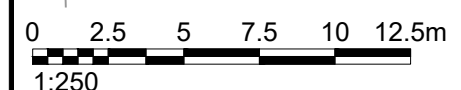

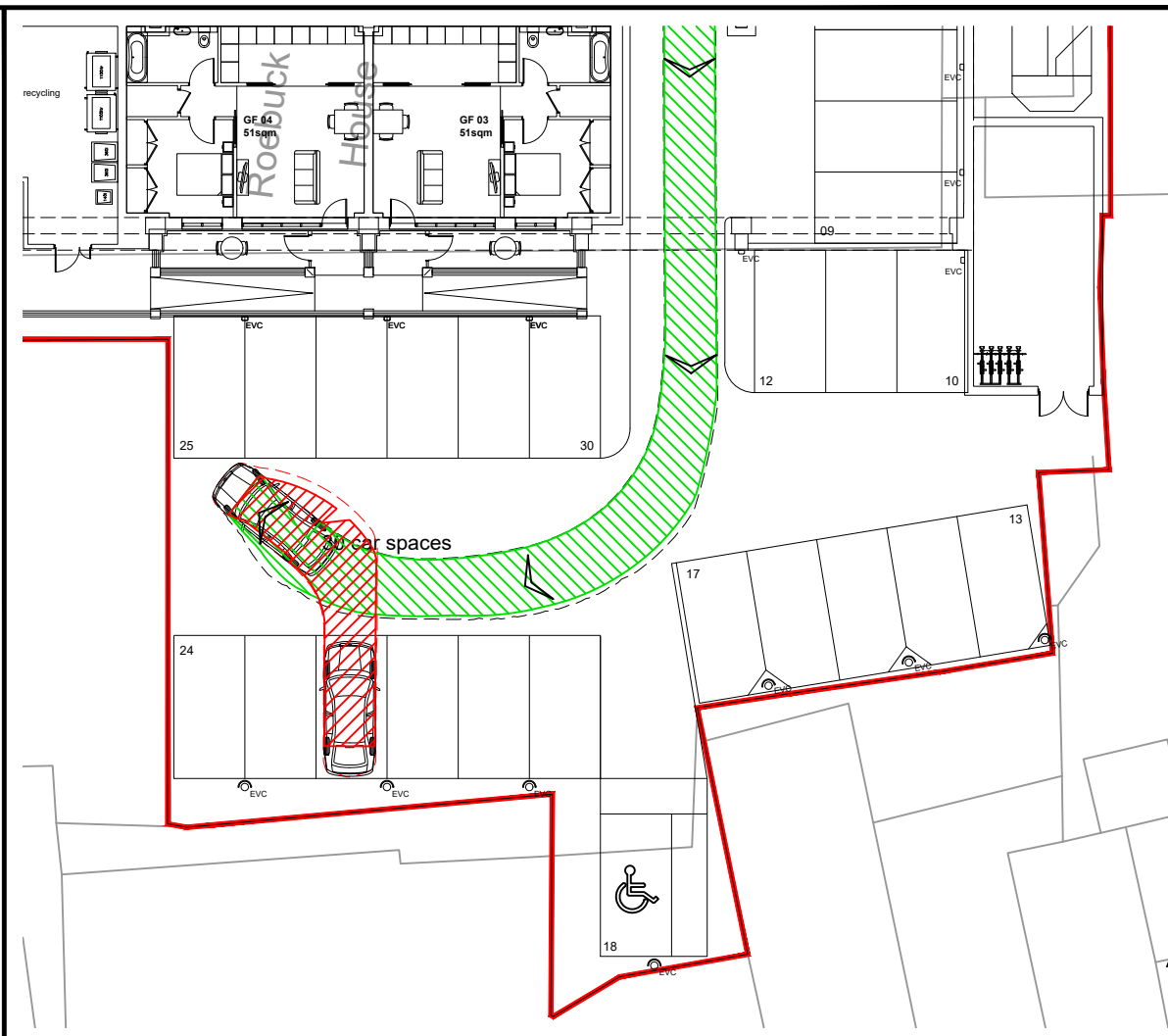
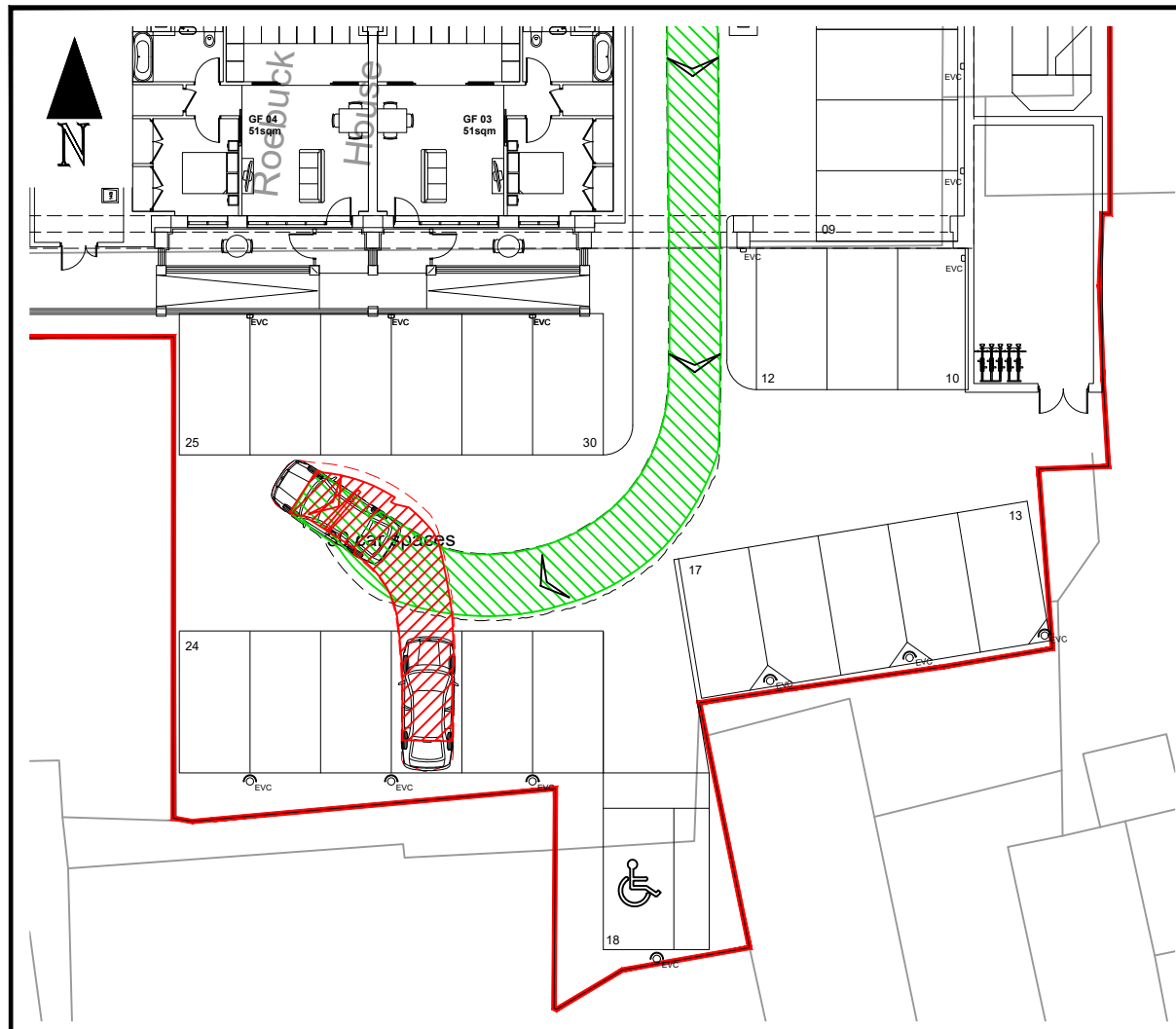

- NOTES:**
1. Do not scale from this drawing.
 2. This drawing to be read & printed in colour.
 3. This drawing is for illustrative purposes only, and not for construction.

MEDIUM SIZE CAR (Skoda Octavia)

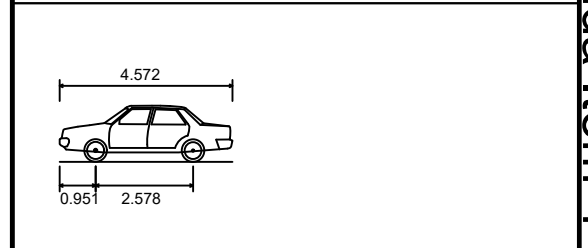

Overall Length	4.572m
Overall Width	1.769m
Overall Body Height	1.488m
Min Body Ground Clearance	0.249m
Max Track Width	1.713m
Lock to Lock Time	4.00s
Kerb to Kerb Turning Radius	5.100m

- FORWARD MOVEMENTS
(design speed - 0.1kph)
- REVERSE MOVEMENTS
(design speed - 0.1kph)

Appendix A

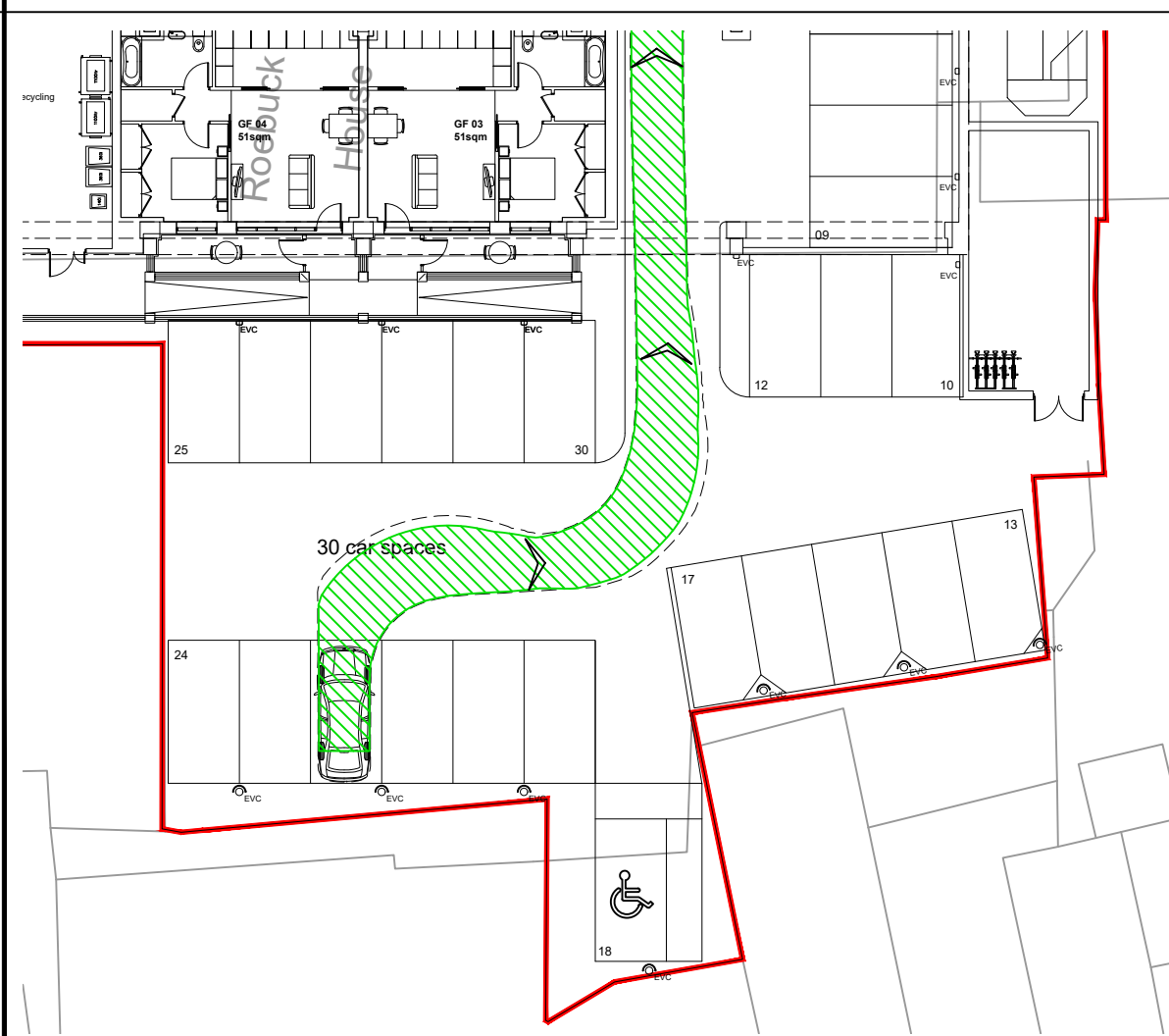
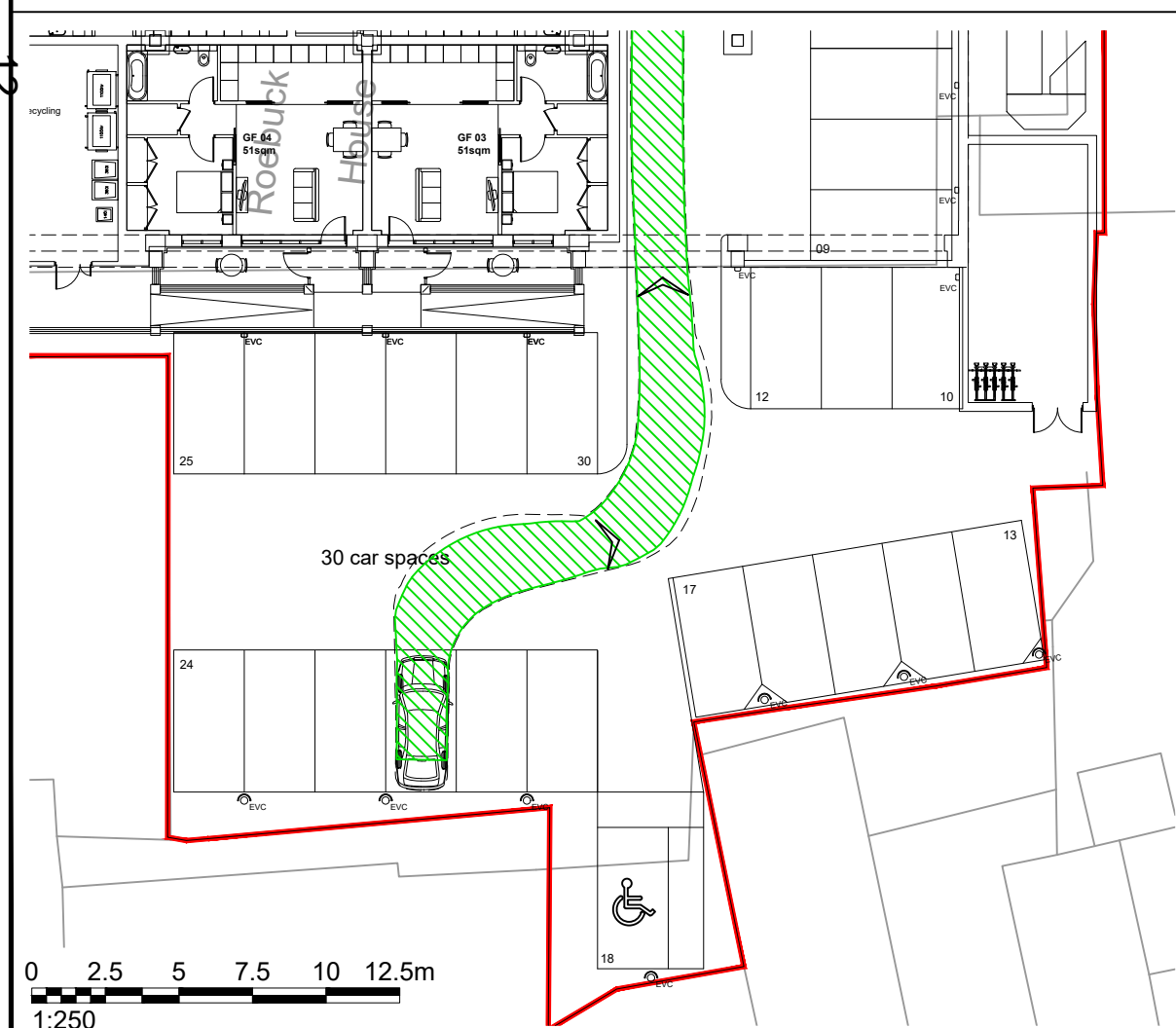

A	Vehicle Tracking Updated	AEG	KH	23.06.23
REV	DETAILS	DRAWN	CHECKED	DATE



CLIENT			
Roebuck Close Ltd			
PROJECT			
Roebuck House, Reigate			
DRAWING TITLE			
Vehicular Swept Paths Analysis using Medium Size Car (Sheet 4 of 6)			
SCALE		SIZE	
1:250		A3	
DRAWN BY	CHECKED BY	DATE	
DW	KH	21.06.2023	
48 Charlotte Street, London, W1T 2NS Tel: 020 3701 0400 www.pulsartransport.co.uk			
PROJECT REF	DWG NO	REV	
21037	TR02 (4)	A	

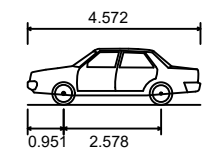

- NOTES:**
1. Do not scale from this drawing.
 2. This drawing to be read & printed in colour.
 3. This drawing is for illustrative purposes only, and not for construction.

MEDIUM SIZE CAR (Skoda Octavia)

	
Overall Length	4.572m
Overall Width	1.769m
Overall Body Height	1.488m
Min Body Ground Clearance	0.249m
Max Track Width	1.713m
Lock to Lock Time	4.00s
Kerb to Kerb Turning Radius	5.100m

	FORWARD MOVEMENTS (design speed - 0.1kph)
	REVERSE MOVEMENTS (design speed - 0.1kph)

Appendix A

A	Vehicle Tracking Updated	AEG	KH	23.06.23
REV	DETAILS	DRAWN	CHECKED	DATE

CLIENT		Roebuck Close Ltd	
PROJECT		Roebuck House, Reigate	
DRAWING TITLE		Vehicular Swept Paths Analysis using Medium Size Car (Sheet 5 of 6)	
SCALE	1:250	SIZE	A3
DRAWN BY	DW	CHECKED BY	KH
DATE	21.06.2023		
			
48 Charlotte Street, London, W1T 2NS Tel: 020 3701 0400 www.pulsartransport.co.uk			
PROJECT REF	21037	DWG NO	TR02 (5)
REV	A		

Agenda Item 4

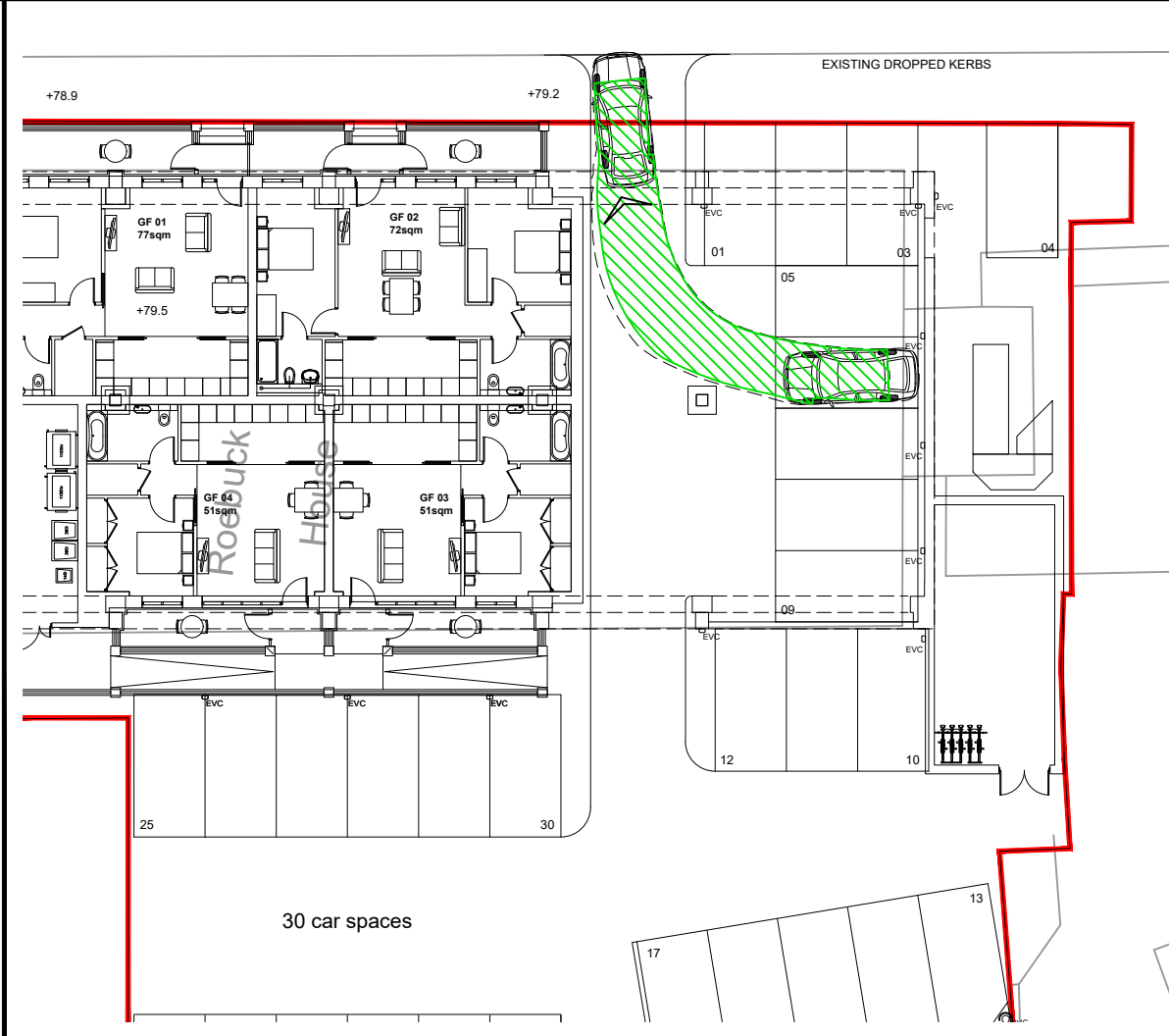
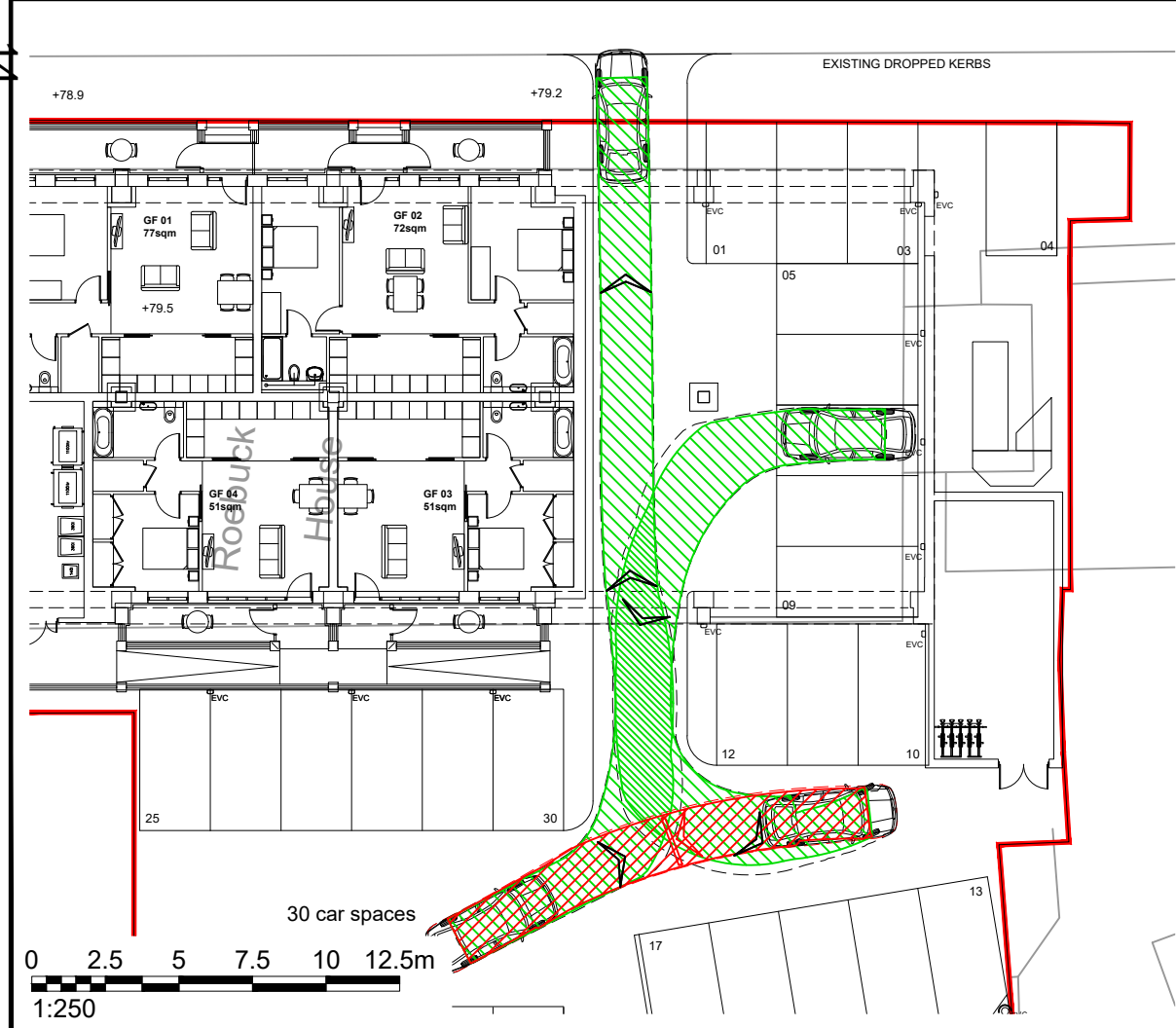
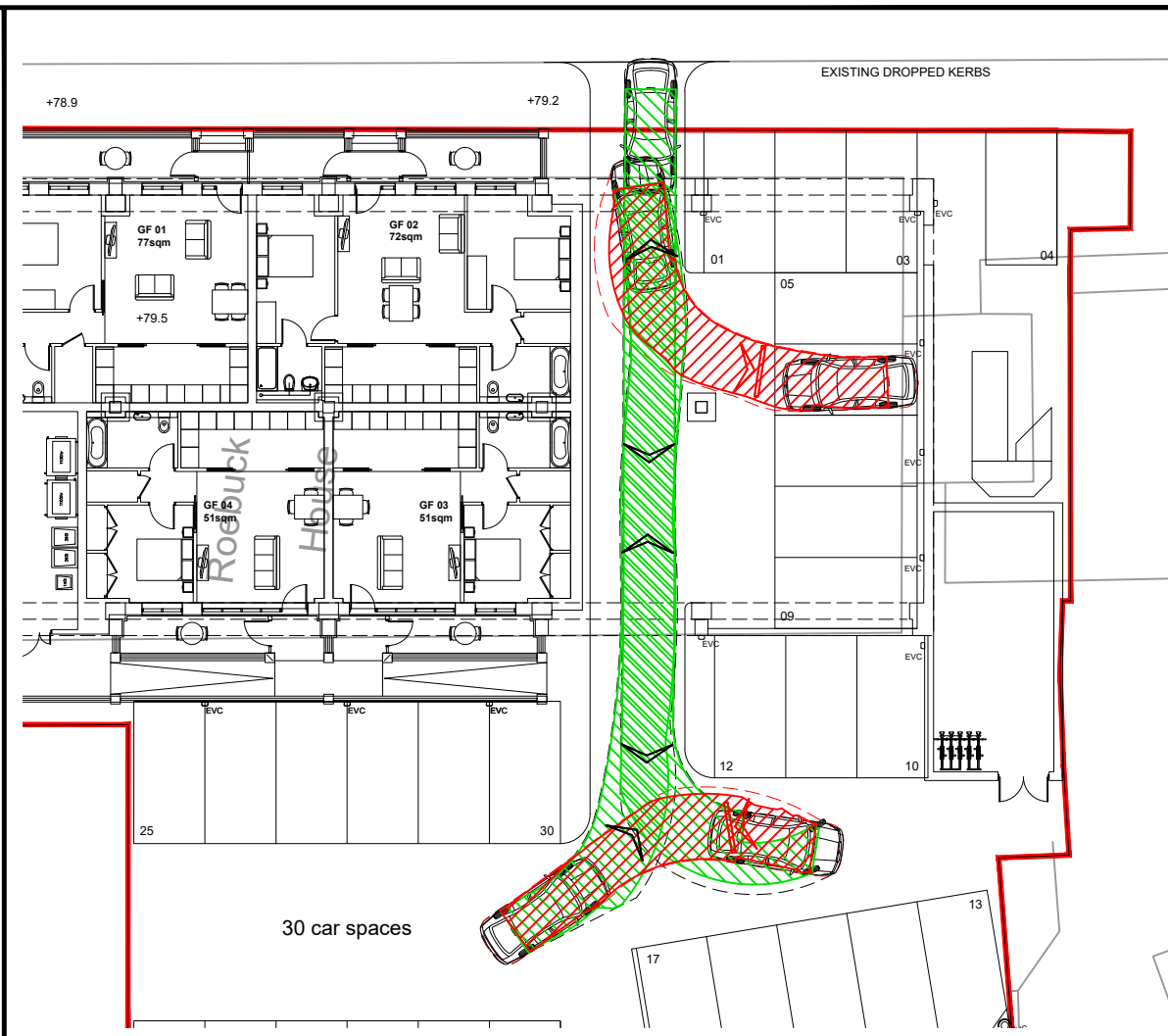
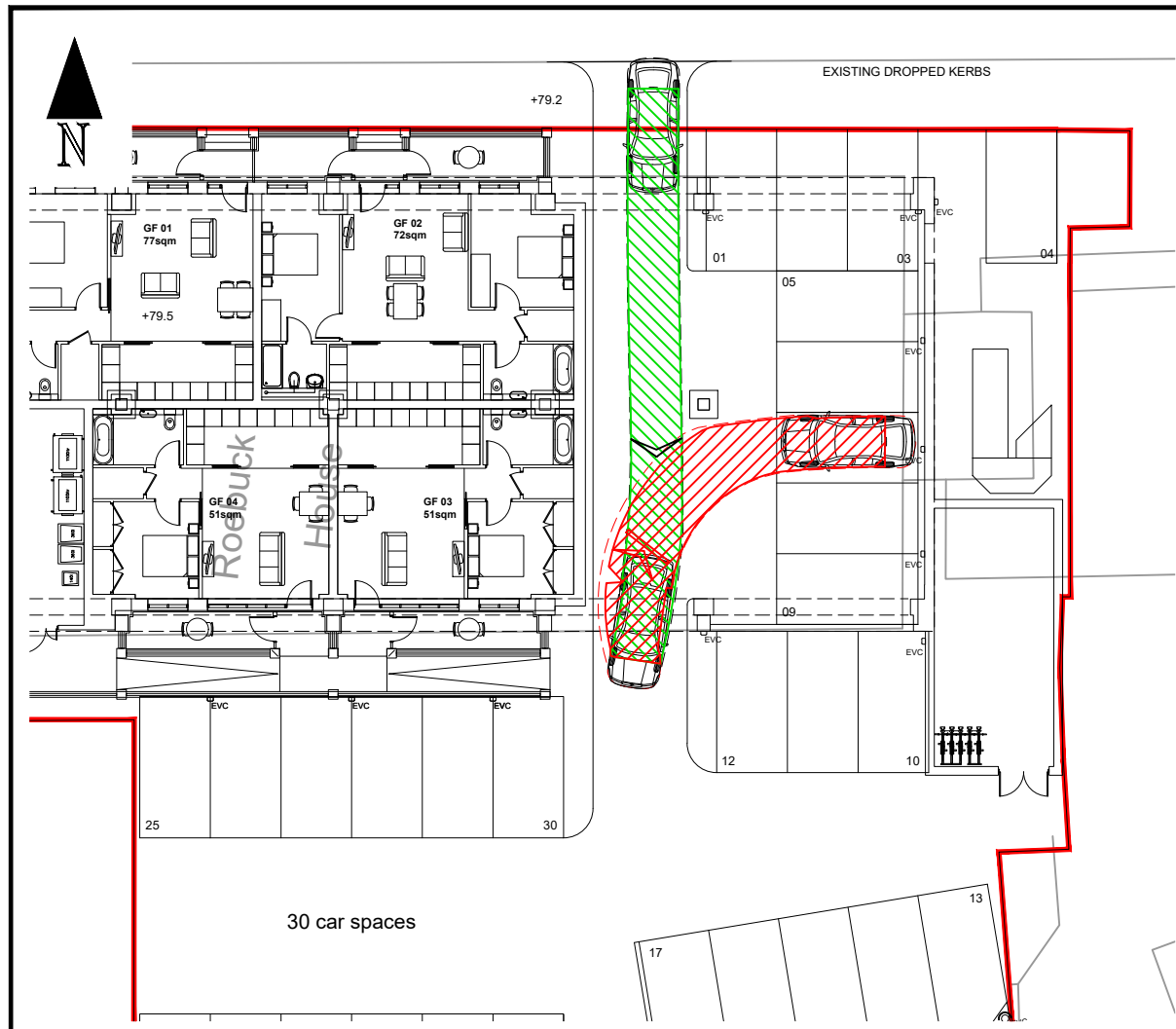

NOTES:

1. Do not scale from this drawing.
2. This drawing to be read & printed in colour.
3. This drawing is for illustrative purposes only, and not for construction.

MEDIUM SIZE CAR (Skoda Octavia)

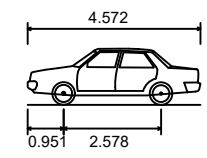

Overall Length	4.572m
Overall Width	1.769m
Overall Body Height	1.488m
Min Body Ground Clearance	0.249m
Max Track Width	1.713m
Lock to Lock Time	4.00s
Kerb to Kerb Turning Radius	5.100m

FORWARD MOVEMENTS
(design speed - 0.1kph)

REVERSE MOVEMENTS
(design speed - 0.1kph)

Appendix A

A	Vehicle Tracking Updated	AEG	KH	23.06.23
REV	DETAILS	DRAWN	CHECKED	DATE

CLIENT
Roebuck Close Ltd

PROJECT
Roebuck House, Reigate

DRAWING TITLE
Vehicular Swept Paths Analysis using Medium Size Car (Sheet 6 of 6)

SCALE
1:250

SIZE
A3

DRAWN BY
DW

CHECKED BY
KH

DATE
21.06.2023

Pulsar
TRANSPORT PLANNING

48 Charlotte Street, London, W1T 2NS
Tel: 020 3701 0400
www.pulsartransport.co.uk

PROJECT REF 21037	DWG NO TR02 (6)	REV A
-----------------------------	---------------------------	-----------------

Appendix B



Appendix B

